

# J+4<sup>™</sup>

## User Guide



### **Stereo -10dB Unbalanced to +4dB Balanced Converter and Line Driver**

Radial Engineering Ltd.  
1845 Kingsway Ave., Port Coquitlam, BC V3C 0H3, Canada  
Tel: 604-942-1001 • Fax: 604-942-1010  
email: [info@radialeng.com](mailto:info@radialeng.com)

## FEATURES

### Input Panel

1. Stereo 1/4" input jacks for -10dB unbalanced sources like DJ mixers.
2. Level control sets the optimum output level for the line driver.
3. Stereo 3.5mm input jack for -10dB unbalanced sources like MP3 players and laptops.
4. Stereo RCA input jacks for -10dB unbalanced sources like CD and DVD players.
5. LED power indicator illuminates when the 15VDC power supply is connected.



### Output Panel

6. Left and right XLR jacks produce a balanced +4dB line-level stereo signal. AES standard pin-2 hot.
7. Power connection for the included 15VDC/400mA supply.
8. Rubber non-slip pad covers the bottom and provides electrical and mechanical isolation.

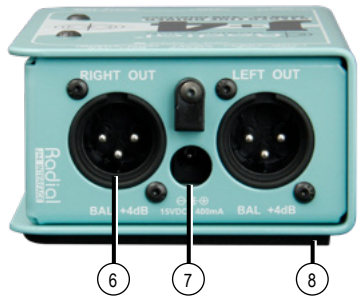

### Side Panel

9. Book-end outer shell protects the jacks and controls from damage.
10. Recessed high-pass filter switch. Reduces low frequencies below 100Hz.
11. Recessed ground lift switch disconnects pin-1 at the XLR to eliminate hum and buzz caused by ground loops.
12. Rugged baked enamel finish for years of good looks.

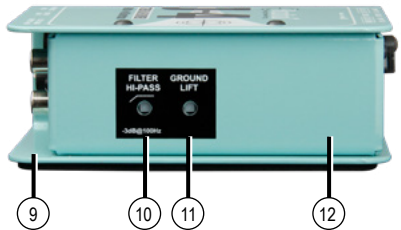

### Inside

13. All connectors are insulated from chassis to reduce noise and crosstalk.
14. Double sided military spec PCB with full ground plane for low noise.
15. Two custom designed Radial isolation transformers eliminates noise caused by ground loops.
16. 14-gauge inner I-beam frame protects the PCB from torque and prevents solder joint failure.

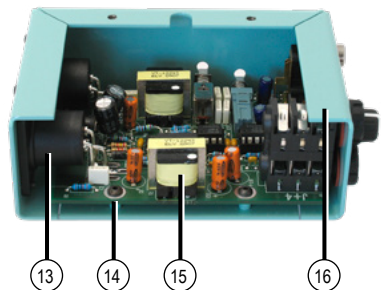

## INTRODUCTION

Congratulations and thank you for purchasing the Radial J+4. This innovative signal converter and line driver offers options and performance designed for the touring engineer, broadcaster, AV integrator and rental company that must regularly interface consumer type audio equipment with pro-audio systems.

This manual contains all the information you need to start using the J+4 right away. Although the J+4 is 'plug and play' easy to use, we suggest you read through it and familiarize yourself with the features to get the most out of your J+4.

Should you have any questions, comments or concerns not covered in these pages, please visit our web site and the J+4 FAQ section. This is where we post the latest details and applications. If you do not find what you need feel free to send us an email at [info@radialeng.com](mailto:info@radialeng.com) and we will do our best to answer your question as quickly as possible.

## OVERVIEW

The Radial J+4 is a stereo interface designed to accept consumer level -10dB unbalanced high impedance signals and convert them to +4dB balanced low impedance signals for easy manipulation in professional audio environments such as broadcast, recording studios and live touring.

Careful attention has been paid to eliminate noise by combining the advantages of active signal buffering with transformer isolation. The J+4 delivers 100dB signal to noise while ensuring hum and buzz caused by ground loops along with spurious noise from digital clocking does not pollute the signal path. Controls include a stereo level control, high pass (low cut filter) and ground lift. A selection of input connectors include a stacked set of 1/4" jacks for DJ mixers or keyboards, RCA's for CD players and a mini 3.5mm for smartphones making the J+4 convenient and quick to use.

As with all Radial products, the Radial J+4 is built tough to handle the most abusive environments. A unique 14-gauge steel I-beam inner frame ensures the sensitive PC board will not be subjected to outside stress which could potentially cause solder joints to fail. An innovative book-end outer shell creates protective zones around the sensitive controls, switches and connectors to further improve dependability while a full bottom no-slip pad provides both mechanical and electrical isolation.

## BLOCK DIAGRAM

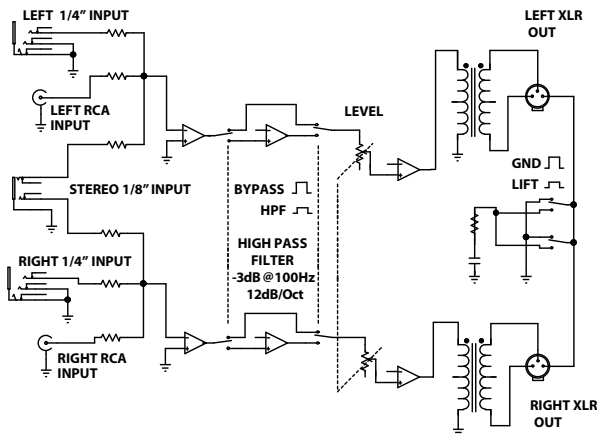

## USING THE J+4

Before connecting, make sure all audio system levels are turned off to avoid any transient popping noise that could harm your speakers. Connect the 15VDC power supply included with the J+4. If your power supply gets lost or damaged, make sure you replace it with an original Radial power supply as the output and polarity are properly matched. Once the power is connected, the front panel power-on LED will illuminate indicating the J+4 is ready to use.

Connect the desired source device (ie: a CD player, smartphone, computer sound card, DJ mixer) to the stereo input jacks on the J+4 using a 1/4" phone, RCA or 3.5mm stereo cable. Since this part of the signal chain is unbalanced it is a good idea to keep these cables under 8 meters (25 feet) to reduce the chance of inducted noise.

Connect the XLR outputs to your mixing console using balanced, twisted pair mic cables. The length of the XLR cables is only limited by the quality of the cable but typical lengths from 100 to 600 meters (300 to 2000ft) are usually not a problem. The J+4 produces a balanced +4dB line-level output allowing you to bypass the mic-preamp stage on your mixer and connect directly to a line input or even drive a power amplifier directly from the J+4.

If your mixer uses 1/4" TRS phone jacks for balanced line inputs you can follow the diagram below to make a TRS to XLR cable that will maintain the balanced connection.

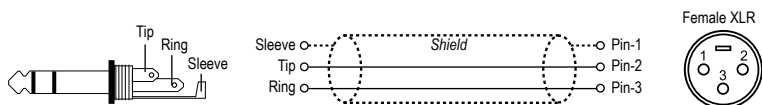

It is always a good idea to test the audio at low levels to make sure all your connections are working properly. Set your audio system to a low level and the level control on the J+4 to zero by turning the level control fully counter-clockwise. Turn on the source device (example: CD player) and slowly turn up the level control on the J+4. If you hear distortion, check to make sure the J+4 is not overloading the input of your console.

### Ground Lift

The J+4 is equipped with a dual ground lift switch that disconnects the pin-1 ground connection on both XLR outputs and prevents ground loops. If you hear hum or buzz, try toggling the recessed 'set & forget' ground lift switch on the side of the J+4 using a tweaker tool.

### Level Control

The LEVEL control sets the output level for both XLR outputs. With a -10dB input signal this level control ranges from infinity to +10.9dB. The J+4 will produce a -7.5dB signal level when the control is at the 12 o'clock position.

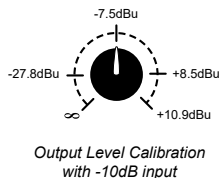

### High Pass Filter

The Radial J+4 is equipped with a high-pass filter that is used to roll-off low frequencies below 100Hz. Bass frequencies contain significantly more energy than higher frequencies. When playing audio tracks through a PA system, reducing bass content with the high pass filter can increase the dynamic range of your audio system. When recording a -10dB source signal, the high pass filter can help clean up a muddy mix by reducing low frequencies.

### APPLICATION 1: Signal level and impedance conversion

The J+4 is used to match the output from an MP3 player to the input of a pro audio system. To get the best sound, the unbalanced -10dB signal is converted up in level to balanced +4dB. The J+4 line level output allows you to connect the MP3 player to auxiliary or tape return inputs saving channel strips for microphones.

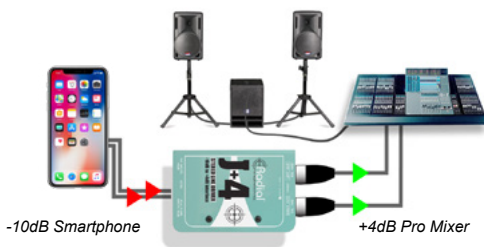

### APPLICATION 2: Line-Driver

The J+4 is used as a signal line-driver for a -10dB consumer CD player located on stage. The active J+4 provides signal level conversion and a buffered balanced output to drive the signal across long cables to a mixer or sound system without significant signal loss.

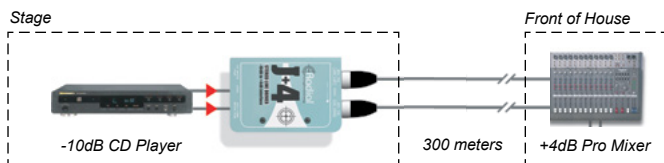

### APPLICATION 3: Signal level and impedance conversion

The J+4 is used to convert signal level and balance the outputs of a satellite TV receiver or connection to integrated audio systems in hotels, sports bars, night clubs and restaurants.

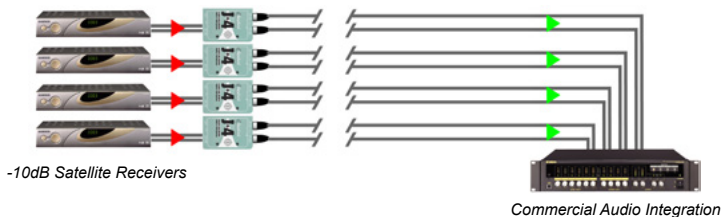

### J-RAK™ AND J-CLAMP™

The optional J-RAK is a high density rack shelf for Radial DI's and splitters. It is a 2RU rack chassis that allows up to 8 Radial devices in one 19" rackmount package. The DI's can be mounted with either the input side or output side facing the front.

The optional J-CLAMP can mount a single Radial J+4 to virtually any surface. Perfect for hiding away inside racks, on podiums or under tables.

### J+4 SPECIFICATIONS

Frequency response:	10Hz ~ 20kHz +/- 1dB (-3dB at 40kHz)
Signal to noise:	>100dB
Input level:	-10dBu typical
Maximum input level:	+17dBu
Maximum output level:	+15dBu
Dynamic range:	100dBu
Total harmonic distortion + noise:	0.004% @ 1k with -10dBu input (+4dBu output)
Channel separation:	>90dB
Self noise:	-95dBu
Input impedance:	10k-Ohms
Output impedance:	600-Ohms typical
High pass filter (low cut):	-3dB at 100Hz
XLR configuration:	AES standard pin-1 ground, pin-2 hot, pin-3 cold
Power supply:	15VDC 400mA center pin positive
Power requirement:	30mA draw
Construction:	14-gauge chassis, outer shell, baked enamel finish
Size:	3.3" x 5.0" x 2" (84 x 127 x 48mm)
Weight:	1.55 lb (720g)

### RADIAL ENGINEERING 3 YEAR TRANSFERABLE LIMITED WARRANTY

RADIAL ENGINEERING LTD. ("Radial") warrants this product to be free from defects in material and workmanship and will remedy any such defects free of charge according to the terms of this warranty. Radial will repair or replace (at its option) any defective component(s) of this product (excluding finish and wear and tear on components under normal use) for a period of three (3) years from the original date of purchase. In the event that a particular product is no longer available, Radial reserves the right to replace the product with a similar product of equal or greater value. In the unlikely event that a defect is uncovered, please call 604-942-1001 or email [service@radialeng.com](mailto:service@radialeng.com) to obtain an RA number (Return Authorization number) before the 3 year warranty period expires. The product must be returned prepaid in the original shipping container (or equivalent) to Radial or to an authorized Radial repair center and you must assume the risk of loss or damage. A copy of the original invoice showing date of purchase and the dealer name must accompany any request for work to be performed under this limited and transferable warranty. This warranty shall not apply if the product has been damaged due to abuse, misuse, misapplication, accident or as a result of service or modification by any other than an authorized Radial repair center.

THERE ARE NO EXPRESSED WARRANTIES OTHER THAN THOSE ON THE FACE HEREOF AND DESCRIBED ABOVE. NO WARRANTIES WHETHER EXPRESSED OR IMPLIED, INCLUDING BUT NOT LIMITED TO, ANY IMPLIED WARRANTIES OF MERCHANTABILITY OR FITNESS FOR A PARTICULAR PURPOSE SHALL EXTEND BEYOND THE RESPECTIVE WARRANTY PERIOD DESCRIBED ABOVE OF THREE YEARS. RADIAL SHALL NOT BE RESPONSIBLE OR LIABLE FOR ANY SPECIAL, INCIDENTAL OR CONSEQUENTIAL DAMAGES OR LOSS ARISING FROM THE USE OF THIS PRODUCT. THIS WARRANTY GIVES YOU SPECIFIC LEGAL RIGHTS, AND YOU MAY ALSO HAVE OTHER RIGHTS, WHICH MAY VARY DEPENDING ON WHERE YOU LIVE AND WHERE THE PRODUCT WAS PURCHASED.